

PRODUCT SPECIFICATIONS

Halsey Taylor HydroBoost® In-Wall Bottle Filling Station, Filtered 8 GPH Stainless. Chilling Capacity of 80LPH (litres per hour) of 50°F drinking water, based on 80°F inlet water and 90° F ambient, per ASHRAE 18 testing. Features shall include Sanitary Sensor Activated, Visual Filter Monitor, Filtered, Green Counter™, Laminar Flow, Antimicrobial, Real Drain. Electronic Bottle Filler Sensor activation. Product shall be Wall Mount (In-Wall Frame/Plate), for Indoor applications, serving 1 station(s). Unit shall be certified to UL 399 and CAN/CSA C22.2 No. 120. Unit shall be lead-free design which is certified to NSF/ANSI 61 & 372 (lead free) and meets Federal and State low-lead requirements.



Special Features:	Sanitary Sensor Activated, Visual Filter Monitor, Filtered, Green Counter™, Laminar Flow, Antimicrobial, Real Drain
Finish:	Stainless Steel
Power:	230V/50Hz
Bubbler Style:	No Bubbler
Activation by:	Electronic Bottle Filler Sensor
Mounting Type:	Wall Mount (In-Wall Frame/Plate)
Chilling Option*:	80 LPH
Full Load Amps	2.28
Rated Watts:	220-240
Dimensions (L x W x H) cm:	23.5 x 38 x 37.5 (cm)
Approx. Shipping Weight:	58.5kg
Installation Location:	Indoor
No. of Stations Served:	1
*Based on 80° F inlet water & 90° F ambient air temp for 50° F chilled drinking water.	

- Touchless, sensor-activation, designed for easy use. Visual Filter Monitor: LED Filter Status Indicator for when filter change is necessary.
- Filter is rated for particulate, chlorine, taste and odor reduction. 3,000 gal. capacity. Green Counter: Informs user of number of 20 oz. plastic water bottles saved from waste.
- Laminar flow provides clean fill with minimal splash.
- Silver Ion Antimicrobial protection on key plastic components to inhibit the growth of mold and mildew.
- Real Drain System eliminates standing water.

AMERICAN PRIDE. A LIFETIME TRADITION. Like your family, the Elkay family has values and traditions that endure. For almost a century, Elkay has been a family-owned and operated company, providing thousands of jobs that support our families and communities.

Included with Product: Bottle Filler
Mounting Frame
Chiller
Filter

PRODUCT COMPLIANCE

ADA
Buy American Act
CAN/CSA C22.2 No. 120
GreenSpec® WRAS
NSF/ANSI 42, 53, 61, and 372 (lead free)
UL 399



5 Year Limited Warranty on the refrigeration system of the unit. Electrical components and water system are warranted for 12 months from date of installation. **Warranty pertains to drinking water applications only. Non-drinking water applications are not covered under warranty.**

PART: _____ QTY: _____

PROJECT: _____

CONTACT: _____

DATE: _____

NOTES: _____

APPROVAL: _____

In keeping with our policy of continuing product improvement, Halsey Taylor reserves the right to change product specifications without notice. Please visit Halseytaylor.com for the most current version of Halsey Taylor product specification sheets. This specification describes a Halsey Taylor product with design, quality, and functional benefits to the user. When making a comparison of other producers' offerings, be certain these features are not overlooked.

Model: ECO-DISPENSER MAX UV - HTHB-1500 (all models) with cut out recessed back.

Product Specifications:

Cabinet material is manufactured from 316L 1.5mm marine grade stainless steel complying to European Standard EN ISO 9445 PO and does not suffer from corrosion and oxidation, does not require any further surface protection (lacquers or paints).

Water Connection Pipe

Includes - 2m Wras approved John Guest or similar water tubing 1/4"
 - Inline water stop tap
 - 15mm - 1/2" BSP female connector

Drain Pipe

Includes - Max length 2.5M, O/D 32mm - I/D 22mm
 Trap not included.

UV LED Steriliser

Flow rate in clear water 4.5 lpm, dosage 30,000µW.sec/cm², minimum pressure required to start up 0.01 bar based on 200 ml/min flow rate, max operating pressure 6.9 bar, UV lamp service life 6000 working hrs, electricity 100V-240V, 50/60HZ - 12V DC, power consumption 9.5 watts.

Water Filtration

Model EWF3000 and 51300C WaterSentry© VII-LeadReduction, Sediment, Taste-Odour Filter Kit

Lead reduction Filter designed for use with Elkay/Hasley Taylor EZH2OTM Bottle Filling Stations with visual filter monitoring. Designed to remove lead particles and chlorine. Also reduces odours and discoloration from incoming water. Quick Disconnect, 1/4 turn installation, automatic inlet shut-off valve that closes when filter is removed. High-grade filter is made with activated carbon and patented ATS lead-removal media. Radial flow-thru design provides more surface area for untreated water while final filter mesh prevents loose carbon from entering water.

Water Filter Recommended Use Conditions

Filter Capacity: 3000 gal. (11356 L) or 1 year.
 Maximum Flow Rate: 1.5 GPM (5.6 L/MIN.).
 Water Temperature: 40 - 100°F (4 - 38°C).
 Initial Pressure Drop: 2-5 PSI (14 - 34 KPa).
 Maximum Line Pressure: 105 PSI (724 KPa).
 Minimum Line Pressure: 20 PSI (138 KPa).

Water Chiller

Housed within the cabinet.

Waste Water Pump (Optional)

Housed within the cabinet.

Power

The cabinet is supplied with 2 x fixed British General 13A 2-Gang RCD switched heavy duty metal clad moulded safety sockets. Trips at 30mA, passive operation that protects against the risk of a fatal shock. Latched with no need to reset after a loss of power.

Power Requirements

We recommend the use of RCD protected socket outlet supplied in the user's premises as an additional safety enhancement.

Top

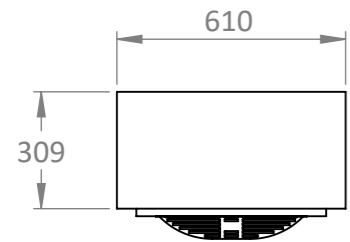

Top

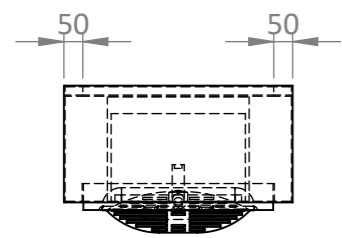

Front

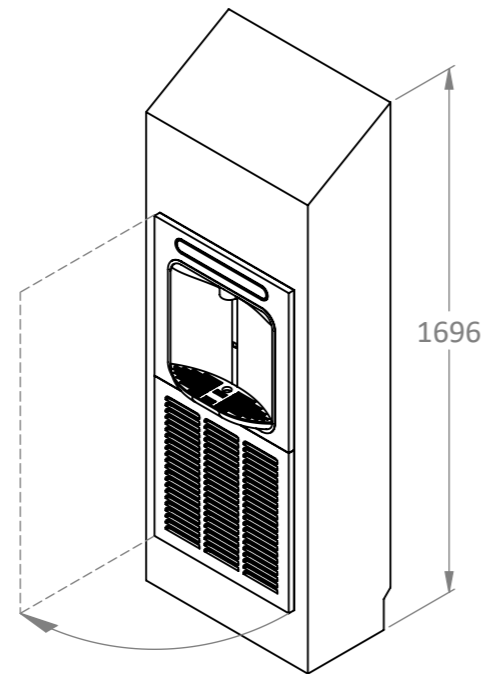

Rear

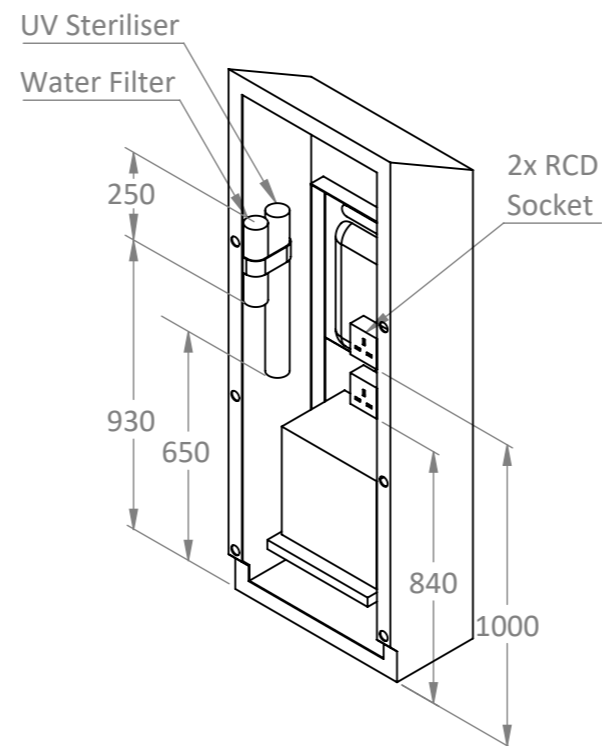

Front

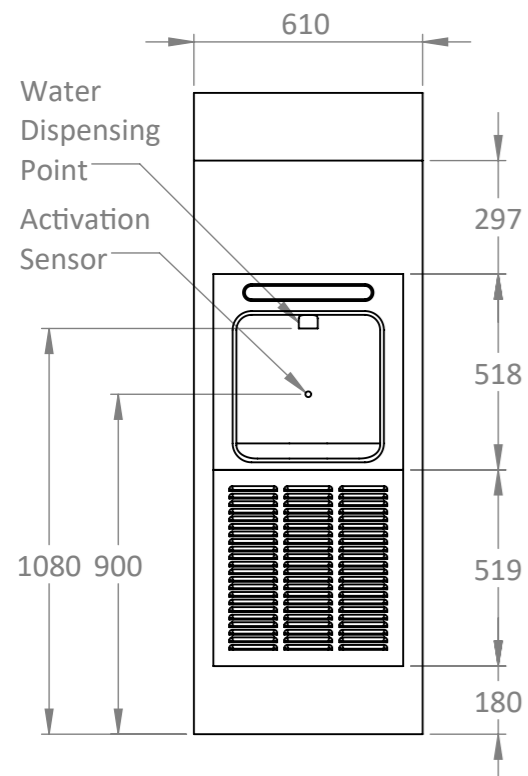

Side

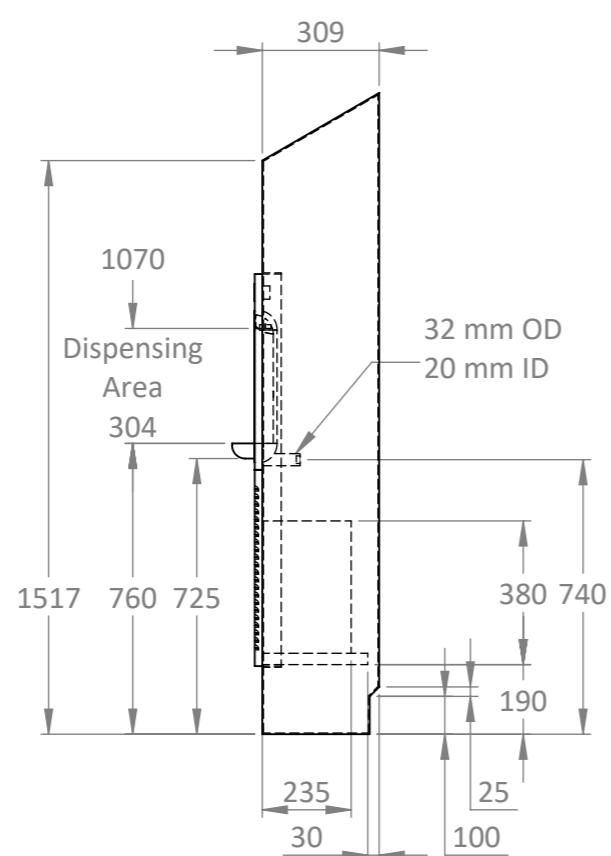

Rear

